

A Comparative Study of Some SN2 Reactions through *ab Initio* Calculations

A. Dedieu and A. Veillard*

Contribution from Université Louis Pasteur, Institut de Chimie, 67-Strasbourg, France. Received February 11, 1972

Abstract: Models for four SN2 reactions have been studied through *ab initio* LCAO-MO-SCF calculations. Results regarding the geometry of the transition state are discussed in connection with the Hammond postulate, the rules given by Thornton, and related experimental results. Results for the intermediate states along the reaction path show that the departure of the leaving ion is relatively late. The reactivities of the F⁻ and H⁻ ions are compared through the computed energy barriers. The electronic structure of the transition state is discussed through the maps of the electron density for localized orbitals and the maps of the differential density. Conclusions drawn from the electron density maps are in agreement with those obtained from the geometric configurations.

An extensive amount of experimental work has been devoted to the bimolecular nucleophilic substitution (SN2) reaction. Theoretical investigations of the corresponding energy surfaces have become feasible only recently either through semiempirical or *ab initio* calculations. Due to the computational limitations, only model reactions occurring *in vacuo* have been considered so far, with the investigation of the energy surface usually restricted to the reaction path assumed from symmetry consideration. For instance, Van der Lugt and Ros¹ have investigated the geometry of the transition state CH₅⁻ for the reaction

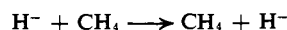

For the same reaction, Mulder and Wright² reported an energy barrier of 69 kcal/mol. The corresponding energy surface has been investigated by Ritchie and Chappell.³ The transition state FCH₃F⁻ for the reaction

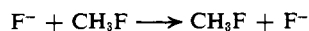

was first found more stable than the reactants by Berthier, David, and Veillard.⁴ This was later traced by Dedieu and Veillard⁵ to a deficiency in the wave function. The above reaction has also been investigated by Duke and Bader⁶ together with the reaction

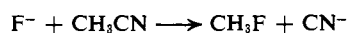

In the former reaction, these authors have computed the geometry and the energy for the reactants, the transition state, and one point along the reaction path close to the transition state. For the latter reaction an approximate geometry is given for the transition state together with an estimate of the energy barrier. Extended Hückel and CNDO calculations have also been reported.⁷

We report here a comparative study of four SN2 reactions. More information of the effect of the nucleo-

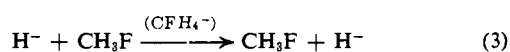

phile and the substituents is gained from a comparison of the results obtained for a set of reactions.

From a quantum mechanical study of the above reactions, we may gain some knowledge of how the geometry, the energy, and the electronic structure of the reactants will evolve along the reaction path. Especially noteworthy are the computed energy barrier and the computed geometry for the transition state. Some of these quantities are accessible experimentally, like the energy barrier, some are not, like the geometry of the transition state. Empirical rules like the Thornton rules or the Hammond postulate have been set up regarding the geometry and the structure of the transition state.

We have used the LCAO-MO-SCF method with a basis set of gaussian functions. Details regarding the computation, the choice of the basis sets, and the geometry optimization have been reported previously with some preliminary results⁸ for reactions 1-3. Computational details regarding reaction 4 are given in the Appendix.

Geometric Configurations

The optimized geometries for several states along the reaction path are given in Tables I-IV for the four reactions. The details of atom numbering are given in Figure 1.

A striking feature is the late departure of the leaving atom in the four reactions. This is apparent from a plot (Figure 2) of the length of the C-F bond (breaking bond) as a function of the length of the C-H' bond (forming bond) in reaction 4. This plot shows a steep rise near the transition state. For instance, when the incoming H⁻ ion in reaction 4 is 1.958 Å from the carbon atom, hence very close to its position in the transition state (at 1.937 Å from the carbon atom, Table IV), the displaced F atom has moved 0.285 Å from its position in CH₃F and is about midway of its

(1) W. Th. A. M. Van der Lugt and P. Ros, *Chem. Phys. Lett.*, **4**, 389 (1969).

(2) J. J. C. Mulder and J. S. Wright, *ibid.*, **5**, 445 (1969).

(3) C. D. Ritchie and G. A. Chappell, *J. Amer. Chem. Soc.*, **92**, 1819 (1970).

(4) G. Berthier, D. J. David, and A. Veillard, *Theor. Chim. Acta*, **14**, 329 (1969).

(5) A. Dedieu and A. Veillard, *Chem. Phys. Lett.*, **5**, 328 (1970).

(6) A. J. Duke and R. F. W. Bader, *ibid.*, **10**, 631 (1971).

(7) D. R. Kelsey and R. G. Bergman, *J. Amer. Chem. Soc.*, **93**, 1953 (1971).

(8) A. Dedieu and A. Veillard, *C. R. Reunion Annu. Soc. Chim. Phys.*, 1970, in press.

Table I. Calculated Geometries for the Reaction $\text{H}^- + \text{CH}_4 \rightarrow \text{CH}_4 + \text{H}^-$

	(CH ₄)				(CH ₅ ⁻)		
$R_{\text{C-H}'}$, Å	∞	5.292	3.704	2.646	2.117	1.852	1.737
$R_{\text{C-H}_4}$, Å	1.085	1.089	1.092	1.103	1.119	1.157	1.737
γ	109° 28'	110° 7'	110° 58'	111° 18'	109° 58'	107° 54'	90°
$R_{\text{C-H}_1}$, Å	1.085	1.084	1.083	1.079	1.074	1.070	1.062

Table II. Calculated Geometries for the Reaction $\text{F}^- + \text{CH}_3\text{F} \rightarrow \text{CH}_3\text{F} + \text{F}^-$

	(CH ₃ F)				(FCH ₃ F ⁻)		
$R_{\text{C-F}_2}$, Å	∞	5.292	3.704	2.646	2.117	1.878	
$R_{\text{C-F}_1}$, Å	1.42 ^a	1.431	1.443	1.467	1.504	1.878 ^a	
γ	107° 30' ^a	107° 58'	108° 30'	107° 50'	104°	90° ^a	
$R_{\text{C-H}_1}$, Å	1.08 ^a	1.079	1.078	1.073	1.067	1.06	

^a Values of ref 4.

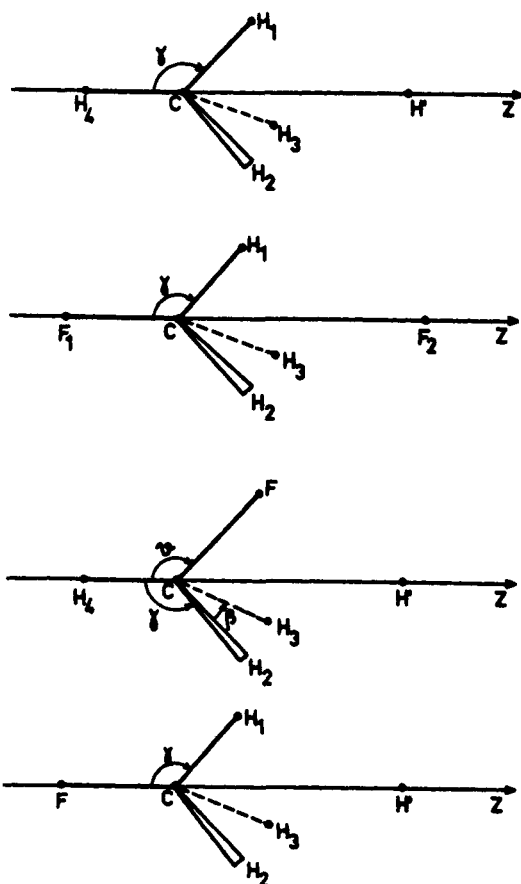
**Figure 1** Geometric configurations for reactions 1-4.

position in the transition state. Kelsey and Bergman⁷ have obtained similar results in their extended Hückel calculations for the $\text{S}_{\text{N}}2$ reactions of H^- on C_2H_6 and C_2H_4 . They raise the possibility that it may be the result of either the approximations inherent in the extended Hückel theory or the assumption of a symmetrical transition state. Since we have reached similar conclusions through *ab initio* calculations, both with and without the assumption of a symmetrical transition state, our results seem to establish firmly that the substrate molecule retains its configuration for as long as possible during the reaction, then undergoes a major structural reorganization in the energy region close to the transition state.

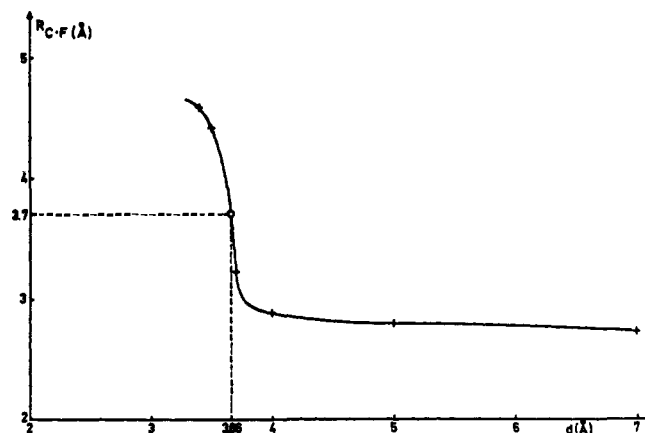
**Figure 2.** Reaction path for the reaction 4: the circle indicates the position of the transition state.

This may also be related to the Hammond postulate⁹ which states that the transition state should resemble closely the reactants in a highly exothermic reaction. From the computed energies for the reactants and the products, reaction is found to be an exothermic process by 68 kcal/mol. Nevertheless, the same phenomenon is also observed for reactions 1-3 which are athermic.

It is found that the angle γ between the breaking bond and the nonreacting bond first increases slightly by a few degrees when the nucleophilic ion approaches, then decreases to the value of 90° in the transition state. In the case of reaction 1, the CH_4 molecule is polarized in the field of the approaching negative ion with a positive charge induced on the nonreacting hydrogen atoms. The increase in the angle γ observed at the beginning of the reaction arises from the corresponding ion-induced dipole interaction (see below the discussion of the energy change along the reaction path). In the cases of reactions 2 and 4, the substrate molecule CH_3F has a permanent dipole moment and the increase in the angle arises from an ion-dipole interaction, the dipole moment being now the sum of a permanent and an induced dipole. In reaction 3, the negative charge on the fluorine atom of the molecule CH_3F induces a repulsive interaction between this fluorine atom and the nucleophilic ion. As a result, the angle between the C-H_4 and C-F bonds in CH_3F decreases monotonically (H_4 being the leaving atom).

(9) G. S. Hammond, *J. Amer. Chem. Soc.*, 77, 334 (1955).

Table III. Calculated Geometries for the Reaction $\text{H}^- + \text{CH}_3\text{F} \rightarrow \text{CH}_3\text{F} + \text{H}^-$

	(CH ₃ F)				(HCFH ₃ ⁻)			
$R_{\text{C-H}}, \text{\AA}$	∞	5.292	3.704	2.646	2.117	1.852	1.601	
$R_{\text{C-F}}, \text{\AA}$	1.08	1.082	1.086	1.095	1.107	1.121	1.601	
θ	107° 30'	105° 39'	103° 35'	100° 51'	98° 7'	96° 37'	90°	
γ	111° 22'	111° 54'	113° 15'	114° 35'	113° 30'	110° 2'	90°	
Φ^a	124° 58'	124° 44'	125° 48'	126° 12'	125° 22'	122° 42'	121° 4'	
$R_{\text{C-H}_2}, \text{\AA}$	1.08	1.079	1.078	1.074	1.068	1.064	1.061	

^a Φ = projection of β on xOy plane.

Table IV. Calculated Geometries for the Reaction $\text{H}^- + \text{CH}_3\text{F} \rightarrow \text{CH}_4 + \text{F}^-$

	(CH ₃ F)				(FCH ₄ ⁻)					
$R_{\text{C-H}}, \text{\AA}$	∞	5.292	3.704	2.646	2.117	1.985	1.958	1.937	1.852	1.799
$R_{\text{C-F}}, \text{\AA}$	1.42	1.431	1.445	1.476	1.524	1.634	1.705	1.958	2.335	2.425
γ	107° 30'	107° 58'	108° 09'	107° 29'	104° 37'	101° 44'	97° 24'	≈90°	80° 36'	78° 55'
$R_{\text{C-H}_1}, \text{\AA}$	1.08	1.079	1.078	1.074	1.069	1.065	1.065	1.063	1.067	1.068

The relationship between a transition state and the reactants or the products⁹⁻¹² may also be discussed in the light of the above results. In agreement with the Hammond postulate,⁹ the transition state for reaction 4 appears closer to the reactant CH₃F than to the product CH₄. The increase for the C-F bond length from the reactant CH₃F to the transition state FCH₄⁻ is 0.54 Å, whereas the decrease in the C-H bond length from the transition state FCH₄⁻ to the product CH₄ is 0.86 Å (Tables I and IV). Haberfield has reported¹² that increasing the basicity of the leaving group moves the transition state closer to the product. It is found that, in the transition states CH₅⁻ and FCH₄⁻ of reactions 1 and 4 (the product being CH₄ for both reactions), the C-H bond length is respectively 1.74 and 1.94 Å. In agreement with Haberfield's conclusions,¹² the transition state CH₅⁻ appears closer to the product CH₄ than the transition state FCH₄⁻ since the H⁻ ion is more basic than F⁻. (From the literature for the ionization potentials,¹³ the electron affinities¹⁴ and the bond energies,¹⁵ the proton affinity of H⁻ in the gas phase is found to exceed the affinity of F⁻ by more than 50 kcal/mol.) Our results seem to disagree with the conclusions of Haberfield that an increase in the basicity of the nucleophile should bring the transition state closer to the reactants. The C-F bond length is closer to its value in the reactant CH₃F (1.42 Å) for the transition state FCH₃F⁻ of reaction 2 (1.88 Å) than for the transition state FCH₄⁻ of reaction 4 (1.96 Å), although the nucleophile F⁻ of reaction 2 is less basic than the nucleophile H⁻ of reaction 4. The same results may be interpreted on the basis of the reactions 2 and 5,

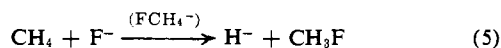

reverse of reactions 2 and 4. Then an increase in the basicity of the leaving group does not appear to move the transition state closer to the product as would be expected from the conclusions of Haberfield. The C-F bond length is closer to its value in the product CH₃F for the transition state FCH₃F⁻ of reaction 2 than

for the transition state FCH₄⁻ of reaction 5, although the leaving group F⁻ of reaction 2 is less basic than the leaving group H⁻ of reaction 5. However one possible reason for this disagreement may be a lack of accuracy in the graphic determination (see Appendix) of the C-F bond length in FCH₄⁻ since the curve of the C-F bond length along the reaction path (Figure 2) is very steep near the transition state.

Reaction 3 has been studied in order to investigate the effect of a nonreacting fluorine atom on the electrophilic center. One possibility is that of a nonlinear arrangement H₁···C···H₂ in the transition state CFH₄⁻. By minimizing the total energy with respect to the angle α between the CH₁ or CH₂ bond and the z axis (Figure 1), we have found that the fluorine atom has no appreciable steric effect. From the values given in Tables I and III, it is found that the axial C···H bond length decreases from 1.74 Å in CH₅⁻ to 1.60 Å in CFH₄⁻. The replacement of a nonreacting hydrogen atom by an electron-withdrawing substituent brings about a shortening of the reacting bonds in the transition state. This conclusion is in agreement with the prediction made by Thornton¹⁰ on the basis of classical mechanics that an electron-withdrawing substituent in the case of a symmetrical transition state must cause a shortening of the reacting bonds (see also ref 11).

For the four reactions, the bonds between the carbon atom and the nonreacting hydrogen atoms are shorter in the transition state than in the reactants. This result is similar to the one found in the inversion process of ammonia¹⁶ and phosphine,¹⁷ with the A-H bond shorter in the planar form than in the pyramidal form. In both processes, the S_N2 substitution reaction and the inversion, the central atom evolves from close to tetrahedral hybridization to close to trigonal hybridization.

Energy Results

We have found an energy barrier (defined as the difference between the total energy of the reactants and the total energy of the transition state) for the four reactions studied here. Computed energy values and the corresponding barriers are given in Table V. The

(10) E. R. Thornton, *J. Amer. Chem. Soc.*, **89**, 2915 (1967).

(11) J. C. Harris and J. L. Kurz, *ibid.*, **92**, 349 (1970).

(12) P. Haberfield, *ibid.*, **93**, 2091 (1971).

(13) C. E. Moore, *Nat. Bur. Stand. (U. S.), Circ.*, **467** (1949).

(14) R. S. Berry, *Chem. Rev.*, **69**, 533 (1969).

(15) T. L. Cottrell, "The Strengths of Chemical Bonds," Butterworths, London, 1958.

(16) A. Rauk, L. C. Allen, and E. Clementi, *J. Chem. Phys.*, **52**, 4133 (1970).

(17) B. Munsch and J. M. Lehn, *Mol. Phys.*, in press.

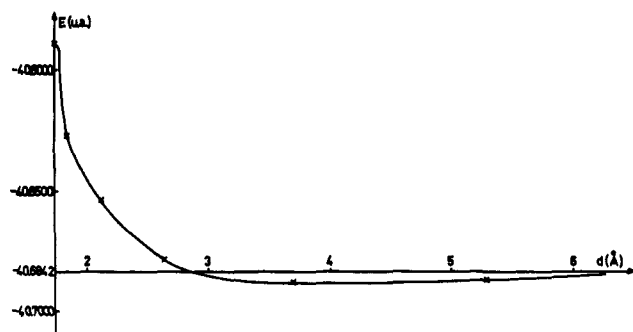

Figure 3. Change in total energy of $\text{CH}_4 + \text{H}^-$ along the path of reaction 1.

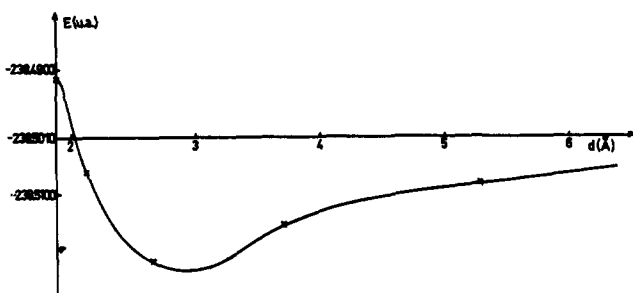

Figure 4. Change in total energy of $\text{CH}_3\text{F} + \text{F}^-$ along the path of reaction 2.

Table V. Energy of the Reactants and of the Transition State for Each Reaction

Reaction	Reactants energy, au	Transition state energy, au	Barrier ΔE , kcal/mol
1	-40.6842	-40.5883	+60.2
2	-238.5276	-238.5150	+7.9
3	-139.5571	-139.4607	+60.5
4	-139.5305	-139.5245 ^a	+3.8

^a Graphically determined (see Appendix).

energy barrier is found one order of magnitude smaller with the F^- ion than with the H^- ion, for a symmetrical transition state (reactions 1 and 2). A comparison of the energy barrier for reactions 1 and 4 indicates that, for a given incoming substituent, F^- is displaced more easily than H^- . In the same way, the comparison of the energy barrier (17.33 kcal/mol) for the reaction $\text{F}^- + \text{CH}_3\text{CN} \rightarrow \text{CH}_3\text{F} + \text{CN}^-$ (from ref 6) and for reaction 2 ($\text{F}^- + \text{CH}_3\text{F} \rightarrow \text{CH}_3\text{F} + \text{F}^-$) indicates that F^- is also displaced more easily than CN^- . This is in agreement with the fact¹⁸ that increasing the basicity¹⁹ of the leaving group makes its displacement more difficult.

The energy barriers computed for reactions 2 and 4 are very close (respectively 5.9²⁰ and 3.8 kcal/mol). The energy decrease observed at the beginning of the reaction is also very similar (*cf.* below). We conclude that the replacement of the F atom in CH_3F proceeds in a similar way for the nucleophile H^- and F^- . The

(18) C. A. Bunton, "Reaction Mechanisms in Organic Chemistry," J. H. Ridd, Ed., Vol. 1, Elsevier, Amsterdam, 1963.

(19) From the same references as previously, the proton affinity of CN^- has been calculated and is found to lie between the proton affinities of F^- and H^- .

(20) This value of 5.9 kcal/mol for the barrier of reaction 2 has been computed with basis set IV,⁸ *i.e.*, with the same basis set which gives the value of 3.8 kcal/mol for the barrier of reaction 4.

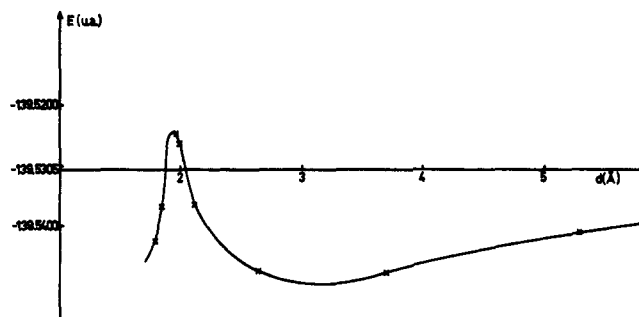

Figure 5. Change in total energy of $\text{CH}_3\text{F} + \text{H}^-$ along the path of reaction 4.

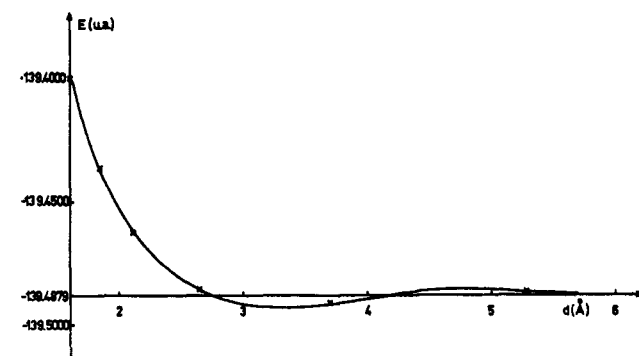

Figure 6. Change in total energy of $\text{CH}_3\text{F} + \text{H}^-$ along the path of reaction 3.

ease of displacement seems to be relatively independent on the basicity of the incoming nucleophile. Edwards and Pearson²¹ have pointed out that the polarizability of the incoming ion is a more important factor than its basicity.

The change in energy along the reaction path is similar for the reactions 1, 2, and 4. The energy decreases first below its value for the reactants, then raises to its value in the transition state (Figures 3–5 and Table VI). The origin of this decrease is to be found in the electrostatic interaction between the charge of the nucleophile and the permanent or induced dipole moment of the substrate. The decrease with respect to the energy value of the reactants is larger in the case of reactions 2 and 4 (respectively 13.2 and 12.2 kcal/mol) than in the case of reaction 1 (3.1 kcal/mol). The permanent dipole moment of the substrate is zero for reaction 1 and different from zero in reactions 2 and 4. The decrease is nearly the same for reactions 2 and 4, which differ only through the nucleophile, but with the same negative charge on this nucleophile.

For reaction 3 (Figure 6 and Table VI), the energy first increases slightly, probably due to the electrostatic repulsion between the nucleophile H^- and the nonreacting fluorine atom of the substrate (which carries a negative formal charge), then it decreases (3.8 kcal/mol) due to the electrostatic attraction with the nonreacting hydrogen atoms, and finally rises to its value in the transition state. A comparison of the energy barriers for reactions 3 and 4 (respectively 60.5 and 3.8 kcal/mol) indicates that the replacement of F in CH_3F is much easier than the replacement of an hydrogen atom. Not

(21) J. O. Edwards and R. G. Pearson, *J. Amer. Chem. Soc.*, **84** 16 (1962).

Table VI. Energy as a Function of the Forming Bond Length d in the Four Reactions

	$d,^a \text{ \AA}$										
	∞	5.292	3.704	2.646	2.117	1.985	1.958	1.878	1.852	1.737	1.601
1	-40.6842	-40.6877	-40.6883	-40.6791	-40.6541				-40.6274	-40.5883 ^{*b}	
2	-238.5010	-238.5085	-238.5153	-238.5210	-238.5067			-238.4916 [*]			
3	-139.4879	-139.4872	-139.4913	-139.4856	-139.4628				-139.4371		-139.3999 [*]
4	-139.5305	-139.5412	-139.5479	-139.5475	-139.5355	-139.5263	-139.5245 [*]		-139.5358		

^a Distances are reported here in \AA . They correspond to round values in au. ^b The asterisk denotes the transition state.

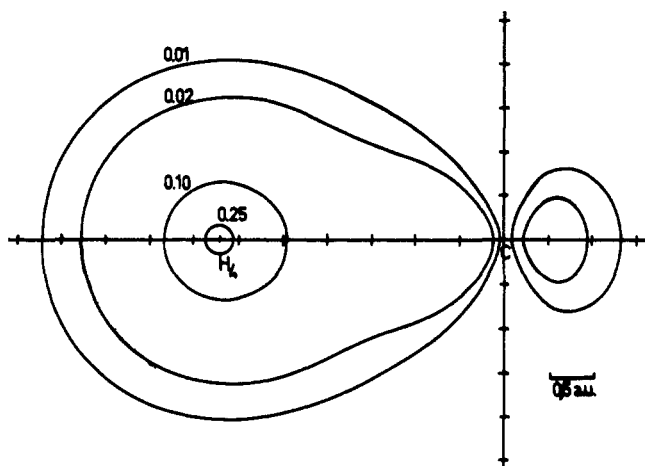

Figure 7. Electron density for the localized orbital corresponding to the C-H₄ bond of the transition state CH₅⁻.

only is the transition state FCH₄⁻ of reaction 4 lower in energy than the transition state CFH₄⁻ of reaction 3, but this is also true for the points along the reaction path.²² One should mention that, while reaction 3 is athermic, reaction 4 is computed to be exothermic by 68 kcal/mol.

Electronic Structure

Information regarding the changes in the electronic structure of the system along the reaction path may be obtained in several ways. The total electron density associated with the wave function has been analyzed previously⁸ for reaction 1. However, it gives no detailed information regarding the change for each bond. This may be obtained by using localized orbitals. Localized orbitals correspond to the usual concept of inner shells, bonds, and lone pairs of chemists. They have been obtained from the SCF orbitals through the method given by Boys.²³ Each bond may then be described through the density map associated with the corresponding localized orbital. The electron density maps for the localized orbitals corresponding to the bonds C-H₄ and C-H₁ of the transition state CH₅⁻ are given in Figures 7 and 8. The C-H₁ bond appears as a typical covalent C-H bond (see for instance ref 24). The axial C-H₄ bond in the transition state is fairly different. The electron density associated with this bond is shifted toward the hydrogen atom (Figure 7). This points to an ionic character for the axial bond C-H₁ in the transition state. This conclusion is corroborated by the change in the position of the center of

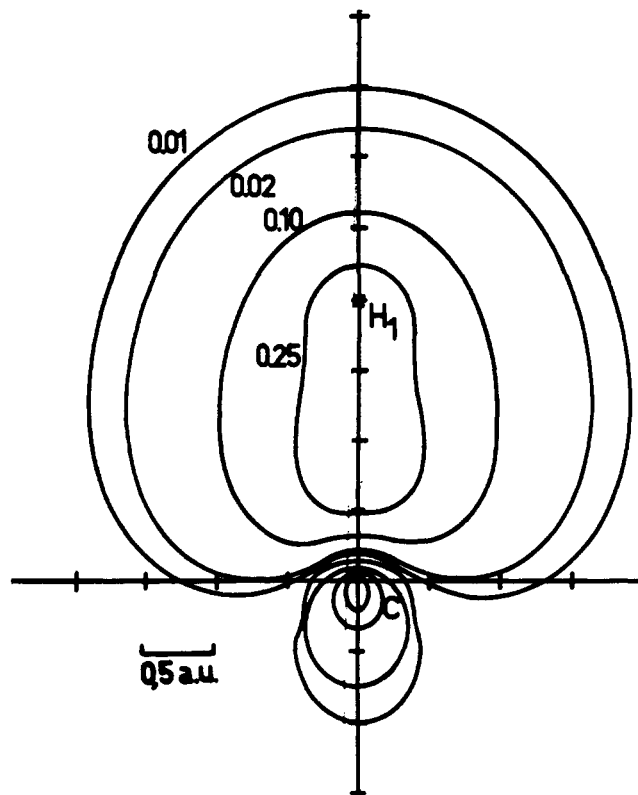

Figure 8. Electron density for the localized orbital corresponding to the C-H₁ bond of the transition state CH₅⁻.

gravity G for the electronic distribution of the localized orbitals (hereafter called "charge center"). The corresponding results for the four reactions are given in Tables VII-X, as the ratio $\rho = CG/CX$, with CG the

Table VII. Variation of the Position of the "Charge Centers" in Reaction 1

Length C-H', \AA	$\rho = CG/CH'$	$\rho = CG/CH_4$	$\rho = CG/CH_1$
∞	1.000	0.661	0.661
5.292	0.982	0.688	0.671
3.704	0.976	0.697	0.668
2.646	1.003	0.711	0.667
2.117	1.041	0.718	0.664
1.852	1.065	0.726	0.662
1.737	0.850	0.850	0.659

distance of the charge center G to the carbon atom and CX the length of the corresponding bond. For reaction 1, the value of ρ associated with the C-H₄ bond increases from a value of 0.66 in CH₄ to 0.85 in the transition state CH₅⁻. The charge center has moved toward the leaving atom and the axial bond appears as fairly ionic (the value of ρ associated with an ionic bond

(22) For the two intermediate states in reactions III and IV with the incoming H⁻ at 2.117 \AA from C and with the same basis set IV,⁸ the energy is lower (-139.5355 au vs. -133.4961 au) when F is the leaving group.

(23) J. M. Foster and S. F. Boys, *Rev. Mod. Phys.*, **34**, 457 (1963).

(24) S. Rothenberg, *J. Chem. Phys.*, **51**, 3389 (1969).

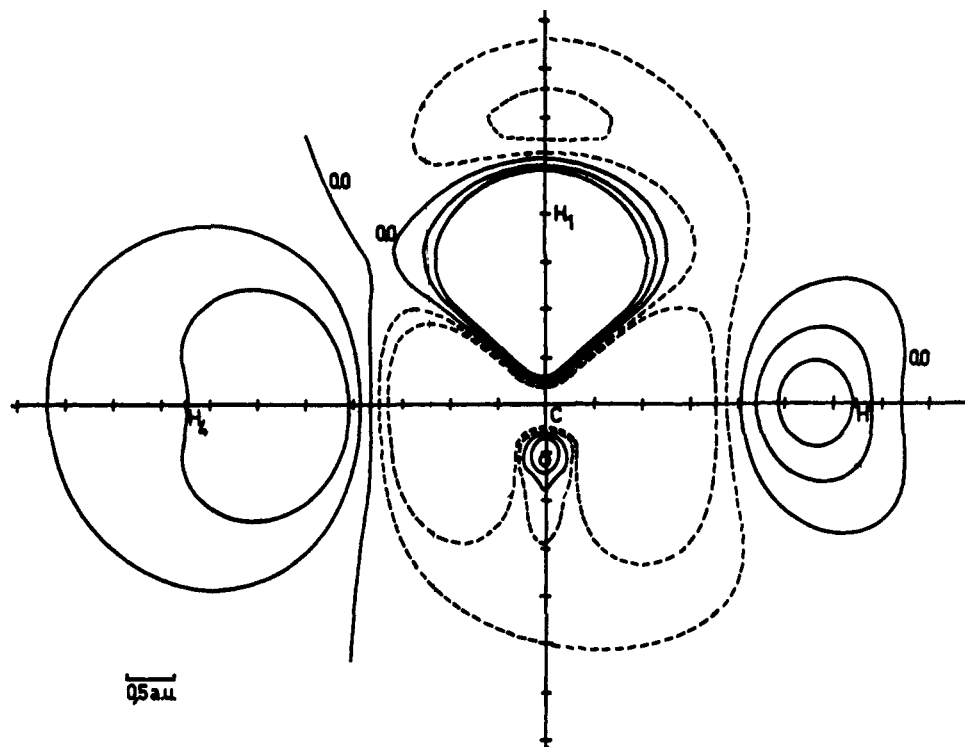

Figure 9. Differential density for CH_5^- in the H_1CH_4 plane. The dotted lines are lines of negative density, the full lines are lines of zero and positive density.

Table VIII. Variation of the Position of the "Charge Centers" in Reaction 2

Length C-F ₂ , Å	$\rho = \text{CG}/\text{CF}_2$	$\rho = \text{CG}/\text{CF}_1$	$\rho = \text{CG}/\text{CH}_1$
∞	1.000	0.671	0.672
5.292	1.000	0.678	0.666
3.704	1.000	0.685	0.670
2.646	0.896	0.697	0.666
2.117	0.861	0.715	0.671
1.878	0.806	0.806	0.663

Table X. Variation of the Position of the "Charge Centers" in Reaction 4

Length C-H', Å	$\rho = \text{CG}/\text{CH}'$	$\rho = \text{CG}/\text{CF}$	$\rho = \text{CG}/\text{CH}_1$
∞	1.000	0.671	0.672
2.646	0.985	0.698	0.665
2.117	0.997	0.714	0.663
1.985	0.972	0.742	0.660
1.958	0.945	0.761	0.660
1.852	0.778	0.868	0.654
1.799	0.662	0.876	0.654

Table IX. Variation of the Position of the "Charge Centers" in Reaction 3

Length C-H', Å	$\rho = \text{CG}/\text{CH}'$	$\rho = \text{CG}/\text{CH}_4$
∞	1.000	0.672
5.292	0.999	0.683
3.704	0.985	0.692
2.646	0.985	0.703
2.117	0.997	0.714
1.852	0.997	0.724
1.601	0.830	0.831

should be close to 1.00). On the contrary the electronic structure associated with the C-H₁ bond involving a nonreacting hydrogen atom remains nearly unchanged along the reaction path, the ρ value being in the range 0.66–0.67. One will notice that the value of ρ for the forming bond C-H' remains close to unity until the nucleophile is near its position in the transition state. The late departure of the leaving atom H₄ is also apparent in the steep rise observed for the corresponding value before reaching the transition state. Rather similar features are associated with the reactions 2–4. For instance, in the three reactions 1, 3, and 4 with a

nucleophile H⁻, the value of ρ for the forming bond C-H remains close to unity along most of the reaction path. In the case of reaction 2 with a nucleophile F⁻, the value of ρ for the forming bond C-F varies in a smoother way.

Further information regarding the rearrangement of the electron density may be obtained from the maps of the differential electron density.²⁵ This is the difference between the total electron density of the system and the sum of the electron densities associated with the atoms in their ground states. Therefore we speak of "negative density" when the sum of the electron densities associated with the atoms is greater than the total electronic density of the system, and of "positive density" in the opposite case. There is some arbitrariness in the differential electron density for a charged system. This is apparent in the differential density map for the transition state of reaction 1 (Figure 9), which shows no symmetry as it would be expected. This comes from the fact that, in the transition state, the negative charge has been arbitrarily associated with the atom H'.

(25) M. Roux, S. Besnainou, and R. Daudel, *J. Chim. Phys.*, **53**, 218 (1956).

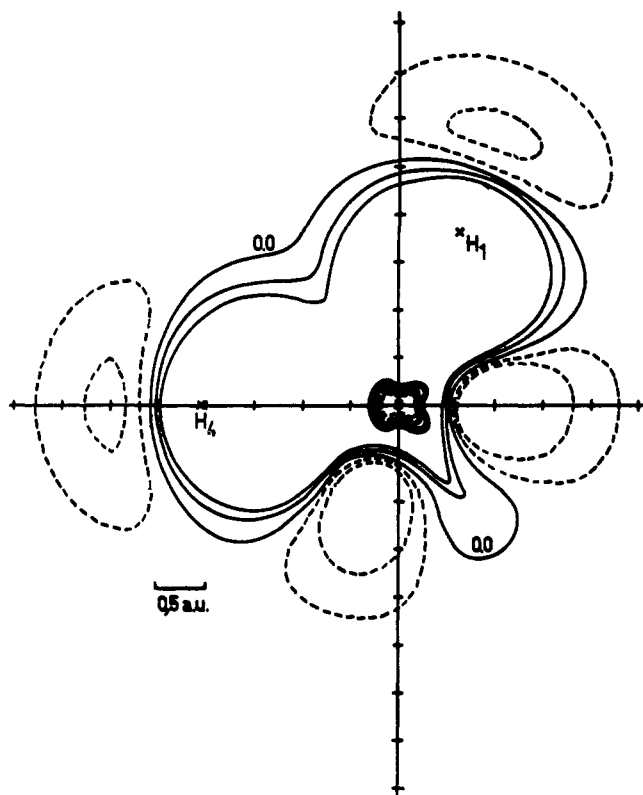

Figure 10. Differential electron density for CH_4 in the H_1CH_4 plane.

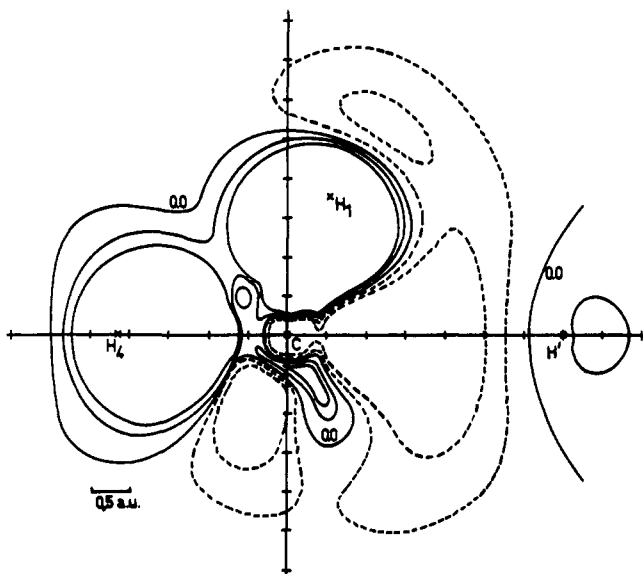

Figure 11. Differential electron density for HCH_4^- in the H_1CH_4 plane with H' at 1.852 \AA from C.

The differential density map for the methane molecule is shown in Figure 10. The buildup of electronic density between the C atom and the H_1 or H_4 atoms is characteristic of a fairly covalent bond.²⁶ The carbon atom is surrounded with a small region of negative density which arises from subtracting the density of a carbon atom in its fundamental state s^2p^2 from the density of a carbon atom sp^3 engaged in four bonds.

(26) R. F. W. Bader, W. H. Henneker, and P. E. Cade, *J. Chem. Phys.*, **46**, 3341 (1967).

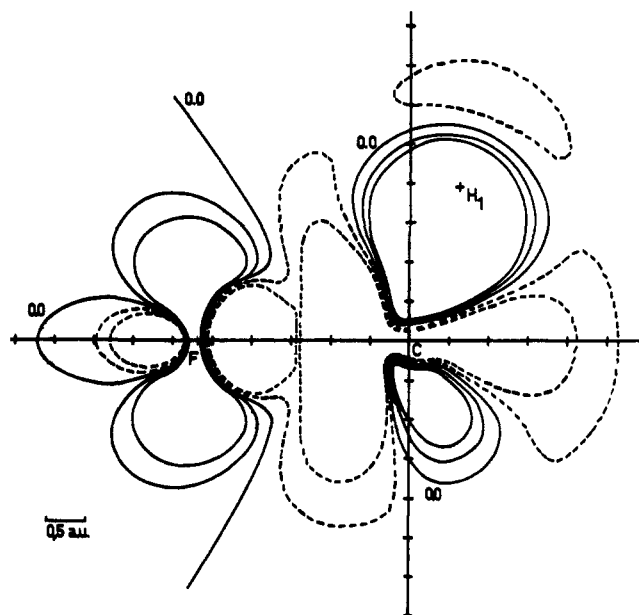

Figure 12. Differential electron density for CH_3F in the H_1CF plane.

There are two regions of negative density on both ends of the C- H_1 or C- H_4 bond. From the differential density for the transition state CH_5^- (Figure 9), the C- H_1 bond appears rather similar to the one in CH_4 . On the contrary, the C- H_4 bond is different from previously. The H_4 and the C atoms are respectively surrounded by two regions of positive and negative density with the zero density contour crossing the C- H_4 axis between the two atoms. Again these features are characteristic of a fairly ionic bond. The same is true of the C- H' bond. A map (Figure 11) of the differential density for one point along the reaction path with the H^- ion at 1.852 \AA from the C atom is rather similar to the one for CH_4 . It only shows a slight polarization of the substrate and the large region of positive density between the C atom and the H_4 atom has not yet developed. This corroborates further the late departure of the leaving atom H_4 .

The map of differential density for CH_3F (Figure 12) shows a region of negative density between the C and F atoms. This is understandable on the basis of first a positive character for the C atom in the C-F bond and second the fact that the F atom in the molecule is in a state close to $s^2x^2y^2z^1$ (with Oz the C-F axis) while we have taken it as $s^2x^{5/2}y^{5/2}z^{3/2}$ for the isolated atom. It is apparent (Figure 13) that in the transition state FCH_3F^- the region of negative density has spread from the C atom to the incoming F atom, while the region of positive density has spread from the leaving F atom to the C atom. This may be interpreted as a transmission of electron density from the incoming nucleophile to the leaving atom.

That the electronic structure of the substrate molecule is not modified until the nucleophile is very close is also apparent in Figure 14. The map of differential density for an intermediate state of reaction 4 with the incoming nucleophile at 2.117 \AA from the carbon atom shows practically no change in the CH_3F region with respect to the map for an isolated CH_3F molecule (Figure 12).

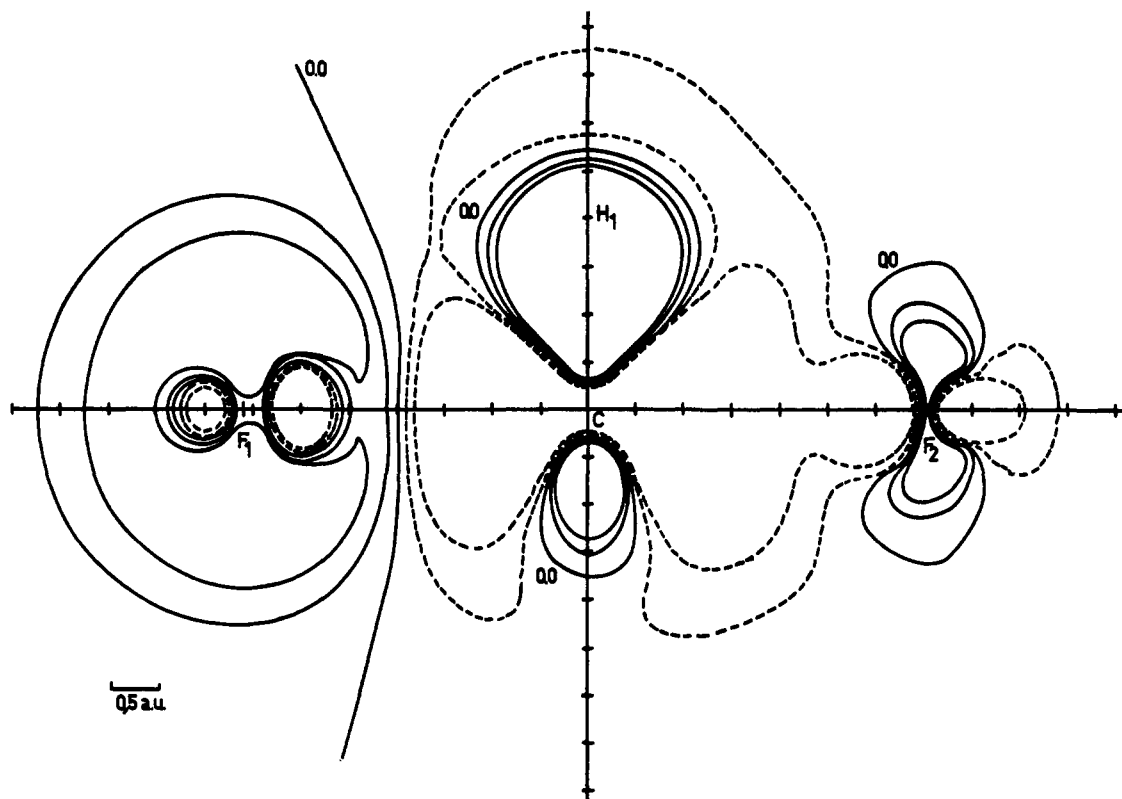

Figure 13. Differential electron density for FCH_3F^- in the H_1CF_1 plane.

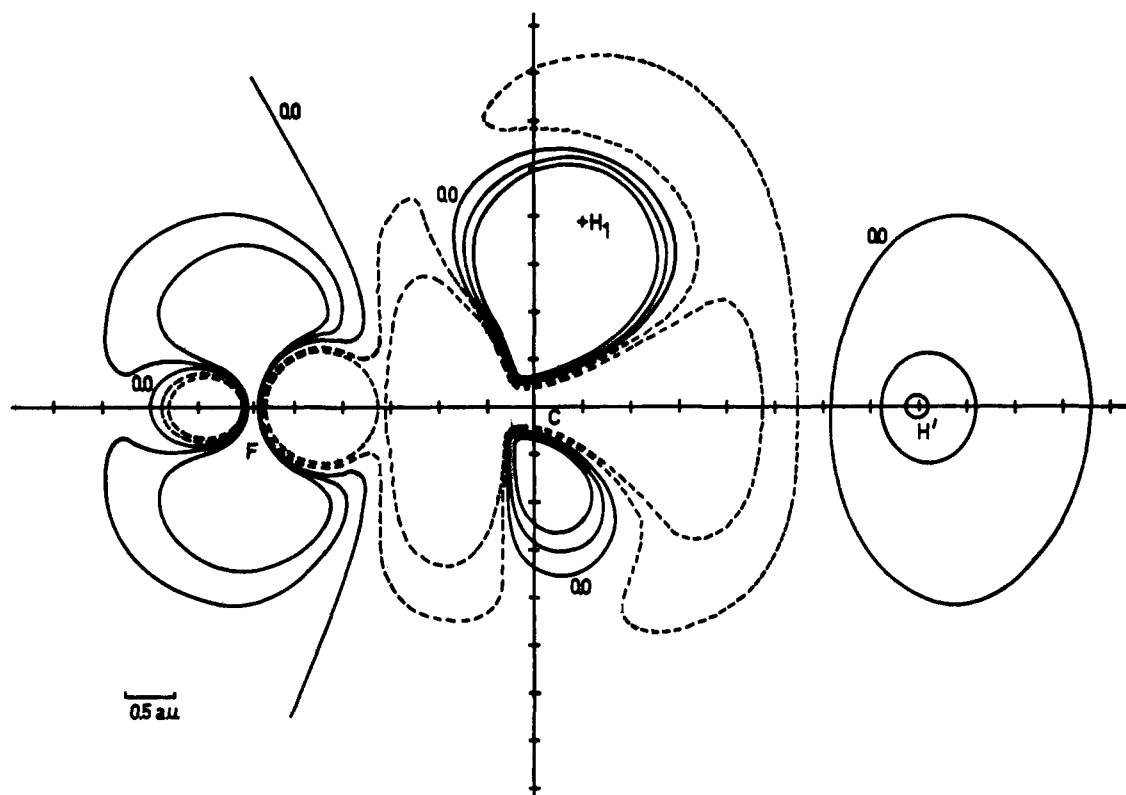

Figure 14. Differential electron density for FCH_4^- in the H_1CF plane with H' at 2.117 \AA from C.

Conclusion

Through *ab initio* quantum mechanical calculations, we have computed the geometry, the energy, and the electronic structure of the transition state in four $\text{S}_{\text{N}}2$

reactions. It has been possible to follow the changes in the geometric configuration along the reaction path. Our results have been obtained with reactions taking place *in vacuo*, in the absence of any solvent effect. The

correlation energy²⁷ (defined as the difference between the Hartree-Fock energy and the nonrelativistic energy) has been assumed to remain approximately constant for the intermediate states along the reaction path since they are isoelectronic closed-shell systems. The effect of correlation energy on the computed energy barriers appears presently as rather difficult to assess.²⁸⁻³⁰

A late departure of the leaving atom has been found for the four reactions, whether athermic or exothermic. Our conclusions are related to the Hammond postulate,⁹ which states that the transition state should resemble closely the reactants in an highly exothermic reaction. They are in agreement with Haberfield's¹² experimental observations, that increasing the basicity of the leaving group moves the transition state closer to the product.

The replacement of a nonreacting hydrogen by an electron-withdrawing substituent like a fluorine atom brings about a shortening of the reacting bonds in the transition state.

Energy barriers have been found for the four reactions. The values obtained (connected with the value given by Duke⁶ and Bader for the reaction $F^- + CH_3CN \rightarrow CH_3F + CN^-$) indicate that, for a given incoming substituent, F^- is displaced more easily than CN^- and H^- . From the energy barriers computed for reactions 2 and 4, the ease of displacement seems to be

(27) P. O. Löwdin, *Advan. Chem. Phys.*, **2**, 207 (1959).

(28) Investigation of the potential energy surface for the reaction $HeH^+ + H_2 = He + H_3^+$, which involves only closed-shell species, indicates that the correlation energy for this system remains constant during the course of the reaction to within 2.5 kcal/mol.²⁹

(29) M. J. Benson and D. R. McLaughlin, *J. Chem. Phys.*, **56**, 1322 (1972).

(30) NOTE ADDED IN PROOF. Limited CI calculations have just been carried out on CH_3F , F^- , and FCH_2F^- .³¹ The contribution to the correlation energy is found to be -0.2804 au for the system $F^- + CH_3F$ and -0.2803 for the FCH_2F^- transition state. Although the perfect agreement between these two numbers is probably fortuitous, this gives some support to the assumption that the correlation energy remains approximately constant along the reaction path.

(31) A. Dedieu, B. Roos, and A. Veillard, unpublished results.

relatively independent of the basicity of the incoming nucleophile.

The study of the changes in the electronic structure along the reaction path confirms the late departure of the leaving atom. Maps of the electron distribution support the postulated scheme for the transition state of a SN_2 reaction as $X^{\delta-} \cdots Y^{\delta 2+} \cdots X^{\delta-}$.

Acknowledgments. We are grateful to the CNRS for a generous donation of computer time at the Centres de Calcul d'Orsay (CIRCE) and Strasbourg-Cronenbourg. We thank the staffs of these computation centers.

Appendix

Determination of the Reaction Path for the Reaction $H^- + CH_3F \rightarrow CH_4 + F^-$. Since this reaction has a nonsymmetrical transition state, it is no longer possible to optimize directly the geometry of the transition state. The transition state is obtained graphically by plotting the potential energy of the system as a function of the distance of the nucleophile H^- . The configurations for the intermediate points on the reaction path are optimized with respect to bond lengths and bond angles within the assumed point group C_{3v} . Minimization of the energy with respect to any parameter is obtained by fitting three points to a parabolic equation. We have found that the variations of the C-F bond length and the γ angle are not independent for states close to the transition state. The optimized configurations are given in Table IV. The total energy of the system as a function of the approach of the nucleophile is given in Table VI and Figure 5. The computed energy for the transition state is -139.524 au for a distance (C-H₂) of 1.937 Å and the optimized parameters $\theta \simeq 90^\circ$, $R(C-F) = 1.96$ Å, and $R(C-H_1) = 1.063$ Å. Optimization of the configurations was done with basis set II of ref 8 and the energy values for the optimized configurations were computed with basis set V.